

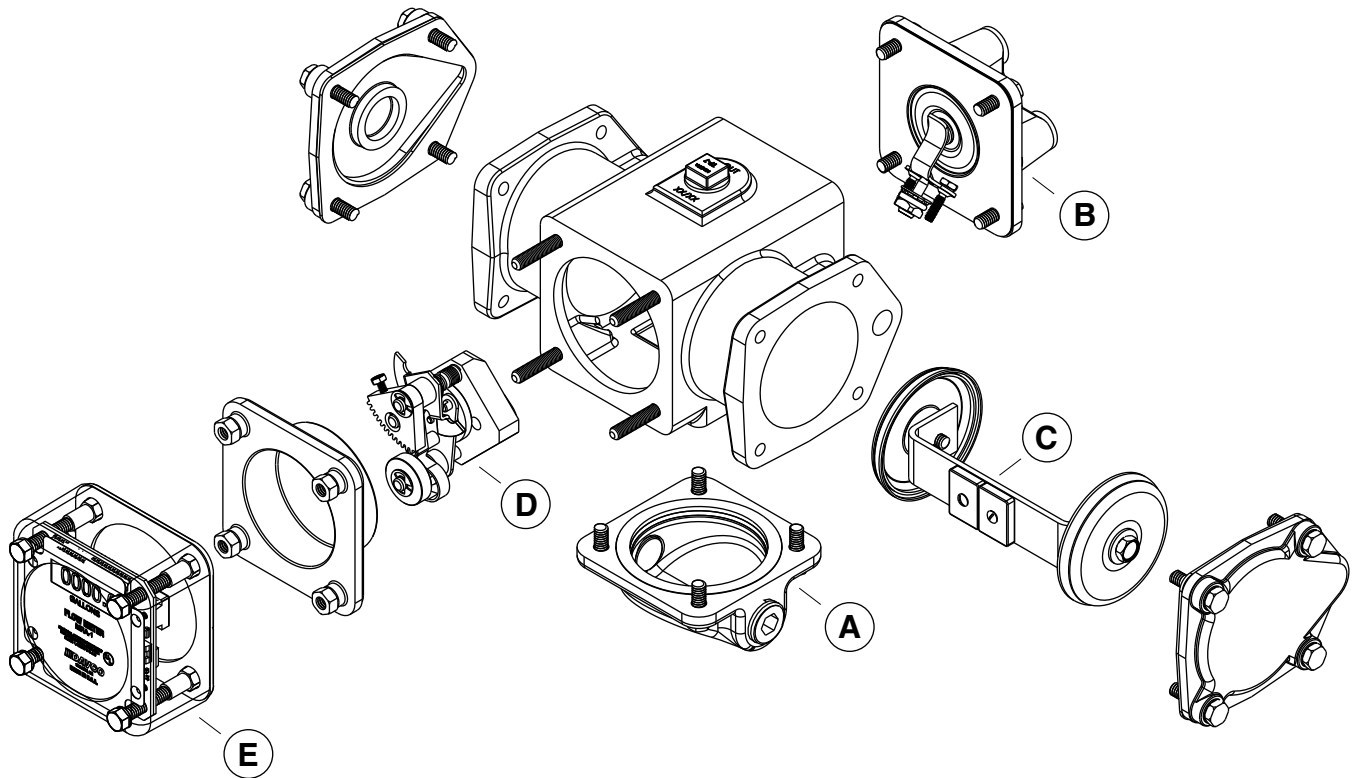

# Intrinsically Safe Meter Installation Instructions

### Parts List

Part	Description	Part Number
A	Inlet Sediment Bowl Kit	3946906 S
B	Pressure Regulator Kit	3945581 S
C	Piston Assembly Kit	3952332 S
D	Cycling Valve Kit	3952436 S
E	Intrinsically Safe Counter Assembly with Digital Readout	See Ordering Information on Page 5
F	Regulator Gasket Set Kit (not shown)	3945217 S
G	Meter Gasket Set Kit (not shown)	3945220 S
H	Screw Set Kit (not shown)	3950385 S



**⚠ CAUTION:** These instructions are intended for use by professional mechanics who are trained in the proper use of power and hand tools, using appropriate safety precautions (including eye protection).

## Introduction

The Fleetguard® REN™ Slow Flow Meter is typically installed in conjunction with the REN™ Oil Level Regulator, but can be used in other applications that require a Slow Flow Meter. The meter is used to accurately measure oil consumption for flows less than 10 gal/hr (37.9 L/hr) on engines and compressors. The two piston, positive displacement design allows slow flow fluid measurements with 0.5% accuracy at extremely low flow rates.

An integral pressure regulator accommodates inlet pressures from 3.5 lb/in<sup>2</sup> (24.13 kPa) to 100 lb/in<sup>2</sup> (689.47 kPa). Outlet pressure is regulated not to exceed a pressure of 2.5 lb/in<sup>2</sup> (24.13 kPa).

## Pre-Installation Notes

- The meter **MUST** be mounted horizontal and top up. The top is plainly marked.
- The meter is designed for stationary applications only.
- Isolate the meter from extreme vibration.
- Locate the meter so that its centerline is neither more than 12" (304.8 mm) below the centerline of the regulator nor more than 48" (1219.2 mm) above the regulator.
- **NEVER** apply air pressure through either the inlet or outlet openings.
- Route pipes and cables away from heat sources or moving components.

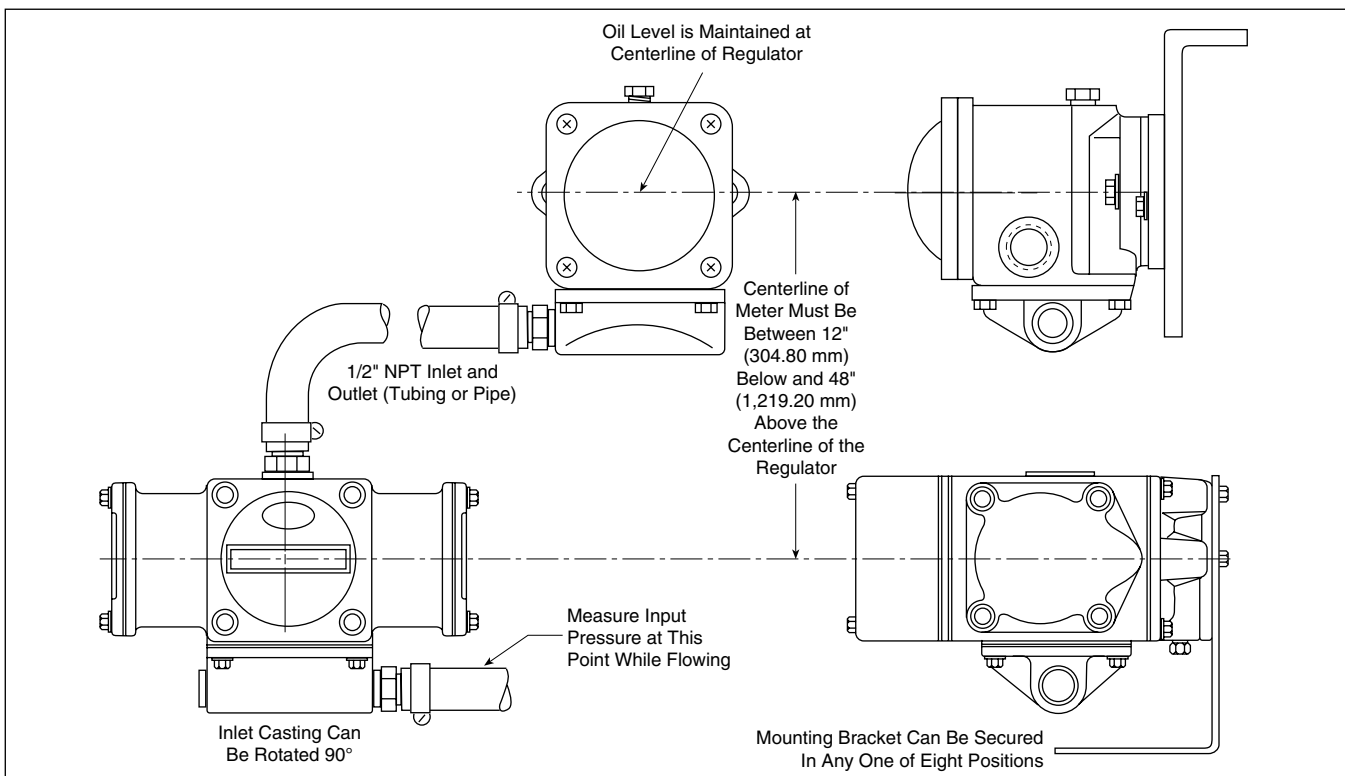

Figure 1 - Installing the Slow Flow Meter

## Installing the Slow Flow Meter

1. Position the provided mounting bracket on an existing member and secure by welding, brazing or bolting into position. The bracket can be secured in any one of eight positions.

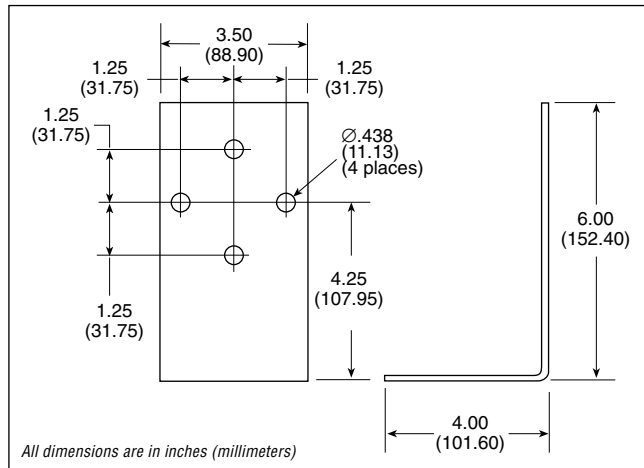

Figure 2 - Mounting Bracket Dimensions

2. Using the 3/8" x 3/4" (9.5 mm x 19.1 mm) cap screws, secure the meter to the mounting bracket. The inlet casting can be rotated 90° if necessary.
3. Connect the supply line to the meter inlet casting at the bottom using 1/2" (12.7 cm) pipe or tubing. Avoid long, unsupported piping which can strain the inlet casting. If long, unsupported piping must be used, make the final connection to the meter using hose selected to handle the incoming pressure.

**Note:** Minimum inlet pressure to the meter should be 3.5 lb/in<sup>2</sup> (24.13 kPa) on flow, but should not exceed 100 3.5 lb/in<sup>2</sup> (689.5 kPa). To determine the height of the hose required to achieve the minimum pressure required, use the following formula:

$$h = 3.5/0.434 \times SG$$

where:

h = height in feet

SG (Specific Gravity) = 0.83 for oil

To convert from feet to meters, multiply the hose length in feet by 0.3048.

4. Connect the oil supply line then remove the plug on the opposite side of the inlet casting at the bottom. Allow any air in the system to be purged. When the fluid is running free and any foreign matter is flushed, replace the plug.

**Note:** Since this is a fluid meter, do not connect it to a supply system containing any appreciable amount of air.

5. Confirm the input pressure while flowing. The measurement should be taken close to the meter (see Figure 1). Excessively long plumbing or systems with many elbows or valves can have significant pressure drop. Therefore, static pressure or pressure readings taken at a distance from the meter can be misleading.

### Installing in a Hazardous Location

A hazardous location includes areas where fire or explosion hazards may exist due to flammable gases, liquids, dust, etc.

**⚠ WARNING:** To prevent personal injury, all standard, necessary precautions should be taken when working in a hazardous environment.

**Note:** Readout Assembly (part number 571203) is intended for hazardous locations Class I, Division I, Groups C and D.

**Note:** Readout Assembly (part number 571203) does not contain field repairable parts. This device shall be removed from the area known to be hazardous if maintenance is required.

**Note:** Substitution of components may impair intrinsic safety.

**⚠ WARNING:** Battery is only to be replaced with the same battery – 3.6 V lithium model LS14500 manufactured by Saft.

Install the Slow Flow Meter with Intrinsically Safe Digital Readout as described in the section entitled, "Installing the Slow Flow Meter."

## Converting From an Analog Counter or Digital Readout to a Intrinsically Safe Digital Readout

**Note:** Perform this conversion in a non-hazardous location.

1. First remove the mechanical counter cover. Remove the four nuts from the barrier casting and remove the analog counter, barrier casting sealing gasket and four studs.
2. Install the new studs, sealing gasket, barrier casting and four aluminum stand off pins. Use a maximum 2 ft-lb (2.71 N-m) torque on the stand-off pins to avoid damaging the case. See Figure 3 (digital) and Figure 4 (analog).

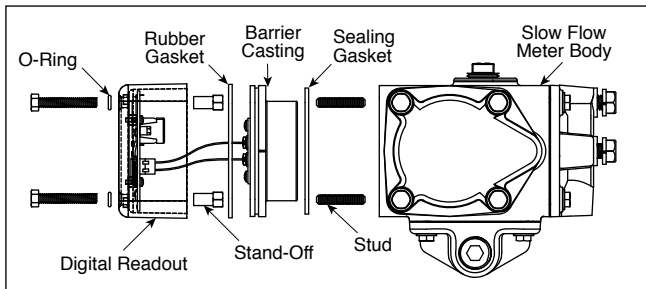

Figure 3 - Converting from a Digital Readout Meter to an Intrinsically Safe Readout Meter

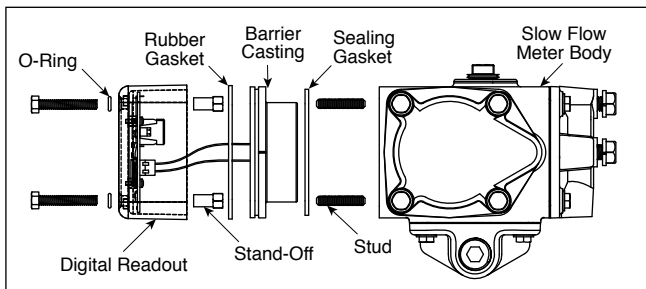

Figure 4 - Converting from an Analog Readout Meter to an Intrinsically Safe Readout Meter

3. For digital meters with barrier plate (see Figure 5):
  - a. There is no polarity on the wires between the Slow Flow Meter and the Readout Assembly.
  - b. Connecting Wires: 22AWG, 6" (152.4 mm) long
  - c. Connecting Wires can be attached to either terminal 1 or terminal 2.

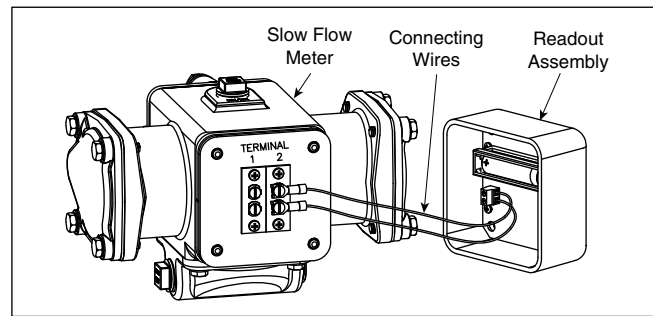

Figure 5 - Mounting the Intrinsically Safe Readout to the Meter with Terminals

4. For direct mount (Figure 6):
  - a. There is no polarity on the wires between the Slow Flow Meter and the Readout Assembly.
  - b. Connecting Wires: 22AWG, 6" (152.4 mm) long
5. Install the Readout Assembly using the four o-rings and bolts provided.

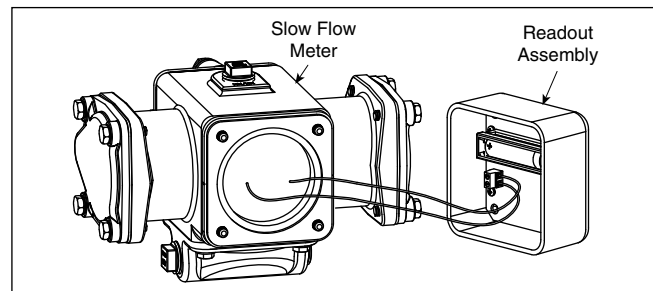

Figure 6 - Mounting the Intrinsically Safe Readout to the Meter Without Terminal (Direct Mount)

## Ordering Information – Slow Flow Meter

Part Number	Description
<b>RN24044</b>	Slow Flow Meter – Intrinsically safe with digital readout (gallon)
<b>RN24045</b>	Slow Flow Meter – Intrinsically safe with digital readout (liter)
<b>RN24026</b>	Slow Flow Meter without display for connection to PLC or remote readout

## Specifications – Slow Flow Meter

Specification	REN™ Slow Flow Meter
Height Overall	7.875" (200.03 mm)
Length Overall	5.375" (136.53 mm)
Width, Max.	8.00" (203.20 mm)
Weight	6.75 lb (3.00 kg)
Max Flow	10 gal/h (37.85 L/h)
Min Inlet Pressure	3.5 lb/in <sup>2</sup> (24.13 kPa)
Max Inlet Pressure	100 lb/in <sup>2</sup> (689.47 kPa)
Accuracy	0.5%

Specifications subject to change without notice.

**Note:** An intrinsically safe device is designed in such way so that energy it holds cannot ignite the gases, vapors or combustible dusts existing in the atmosphere of the designated area. Our Intrinsically Safe readout was approved for use in areas where flammable gases may be present in sufficient quantities to produce explosive or flammable mixtures. In those areas, flammable gases, vapors, liquids, combustible dusts or ignitable fibers are likely to exist under normal operating conditions. Atmosphere may contain ethyl-ether vapors, ethylene, or cyclo-propane, gasoline, hexane, naphtha, benzene, butane, propane, alcohol, acetone, benzol, lacquer solvent vapors, or natural gas.

## Mounting/Dimensions – Slow Flow Meter

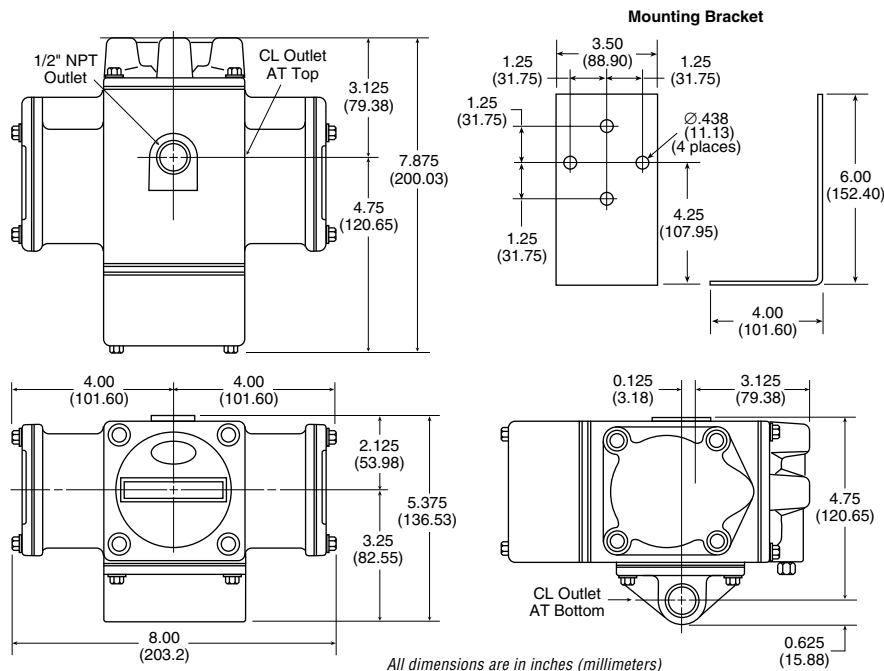

## Ordering Information – Intrinsically Safe Readout

Part Number	Description
3946512 S	LCD Single Readout Only (Liters)
3945222 S	Kit, LCD Remote Readout
3953480 S	Five Year Life Lithium Battery

## Specifications – Intrinsically Safe Readout

Specification	Slow Flow Meter Remote Readout
Height	3.375" (85.7 mm)
Depth Overall	1.75" (44.5 mm)
Width, Max.	5" (127.0 mm)
Weight	1 lb (0.45 kg)
Count, Max.	9999.9 gal or 9999.9 L in 0.05 gal (0.25 L) Increments
Readout	Volume or Volume vs Time
Accuracy	0.5%

Specifications subject to change without notice.

## Mounting/Dimensions – Intrinsically Safe Readout

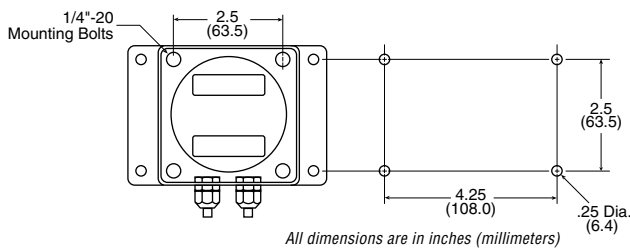

## Typical Installation

